

 Aliaxis



CM DN 12÷15

PP-H

Compact diaphragm valve

CM DN 12÷15

The CM is a manually operated diaphragm valve of reduced dimensions and particularly compact structure, ideal for use in confined spaces.

COMPACT DIAPHRAGM VALVE

- Connection system for solvent weld joints
- Extremely compact construction
- **Internal components in metal totally isolated from the conveyed fluid**
- Valve stem in STAINLESS steel
- **Compressor with floating diaphragm carrier**
- Easy to replace diaphragm seal
- Corrosion-proof internal components
- **Innovative CDSA** (Circular Diaphragm Sealing Angle) system offering the following advantages:
 - uniform distribution of shutter pressure on the diaphragm seal
 - reduction in the tightening torque of the screws fixing the actuator to the valve body
 - reduced mechanical stress on all valve components (actuator, body and diaphragm)
 - easy to clean valve interior
 - low risk of the accumulation of deposits, contamination or damage to the diaphragm due to crystallisation
 - operating torque reduction

Technical specifications	
Construction	Compact single wear diaphragm valve
Size range	DN 12 ÷ 15
Nominal pressure	PN 6 with water at 20 °C
Temperature range	0 °C ÷ 60 °C
Coupling standards	<p>Solvent welding: EN ISO 1452, EN ISO 15493, BS 4346-1, DIN 8063, NF T54-028, ASTM D 2467, JIS K 6743. Can be coupled to pipes according to EN ISO 1452, EN ISO 15493, DIN 8062, NF T54-016, ASTM D 1785, JIS K 6741.</p> <p>Thread: ISO 228-1, DIN 2999, ASTM D 2464, JIS B 0203.</p>
Reference standards	<p>Construction criteria: EN ISO 16138, EN ISO 1452, EN ISO 15493</p> <p>Test methods and requirements: ISO 9393</p> <p>Installation criteria: DVS 2204, DVS 2221, UNI 11242</p>
Valve material	<p>Body: PVC-U</p> <p>Bonnet and handwheel: PA - GR</p>
Seal material	EPDM, FKM, PTFE
Control options	Manual control; pneumatic actuator

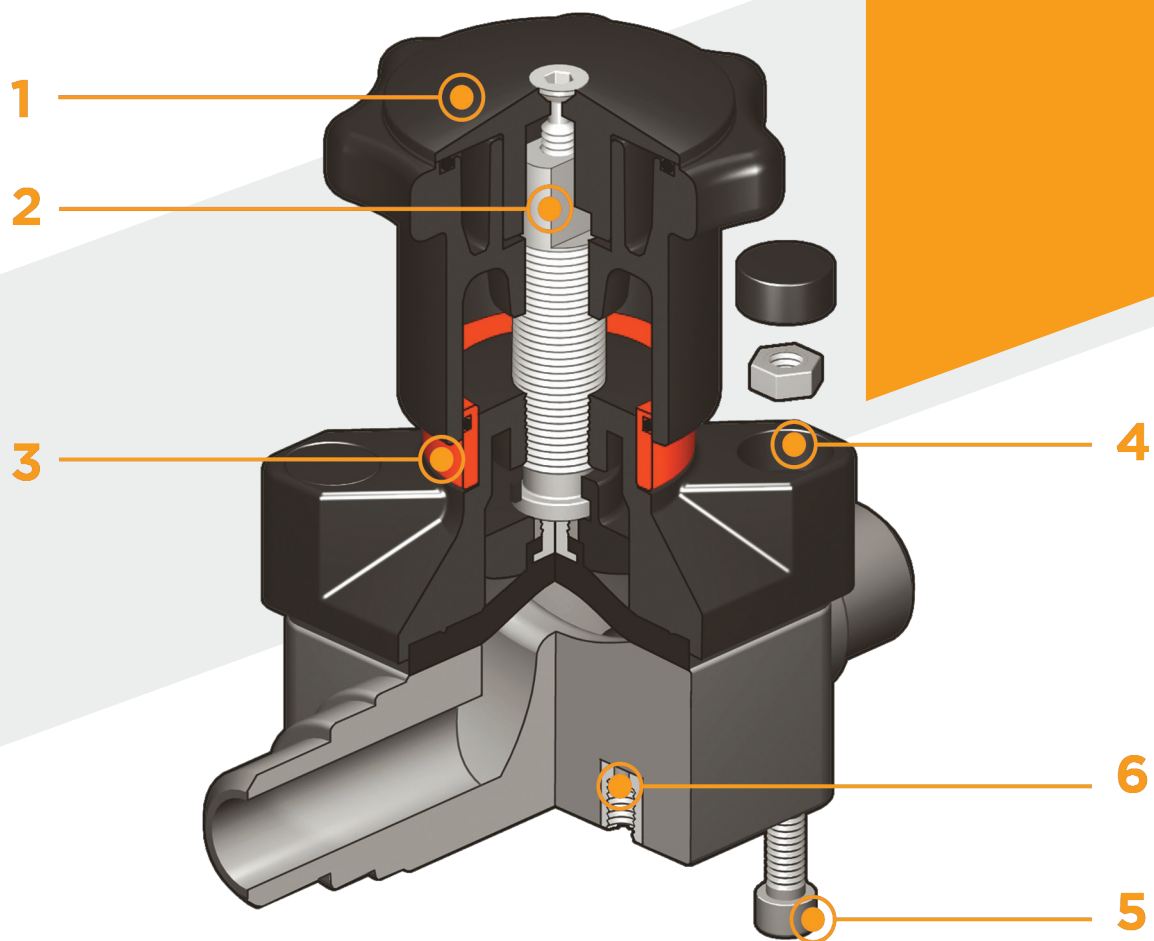

1 Handwheel in PA-GR, completely sealed, high mechanical strength with ergonomic grip for optimum manageability

2 Integrated adjustable torque limiter designed to prevent excessive compression of the diaphragm and always guarantee a minimum fluid flow

3 Optical position indicator supplied as standard

4 Bonnet in PA-GR with STAINLESS steel nuts fully protected by plastic plugs to eliminate zones where impurities may accumulate. Internal circular and symmetrical diaphragm sealing area

5 STAINLESS steel bolts, can also be inserted from above

6 Threaded metal inserts for anchoring the valve

TECHNICAL DATA

PRESSURE VARIATION ACCORDING TO TEMPERATURE

For water and non-hazardous fluids with regard to which the material is classified as CHEMICALLY RESISTANT. In other cases, a reduction of the nominal pressure PN is required (25 years with safety factor).

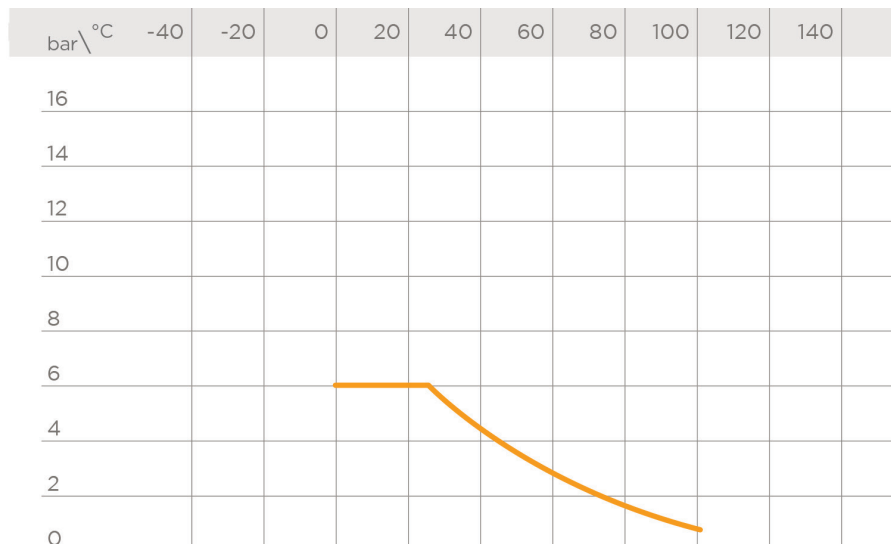

PRESSURE DROP GRAPH

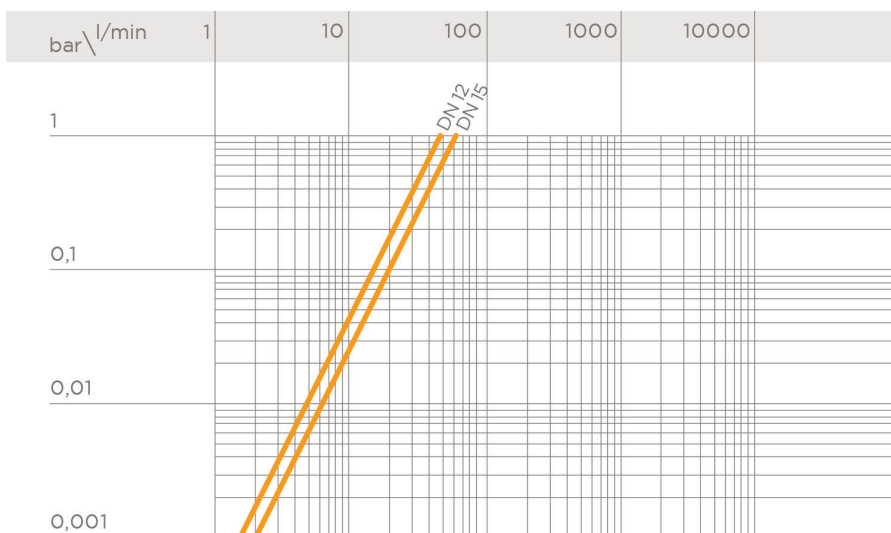

K_v100 FLOW COEFFICIENT

The K_v100 flow coefficient is the Q flow rate of litres per minute of water at a temperature of 20°C that will generate Δp= 1 bar pressure drop at a certain valve position. The Kv100 values shown in the table are calculated with the valve completely open.

DN	12	15
Kv100 l/min	47	60

The information in this leaflet is provided in good faith. No liability will be accepted concerning technical data that is not directly covered by recognised international standards. FIP reserves the right to carry out any modification. Products must be installed and maintained by qualified personnel.

DIMENSIONS

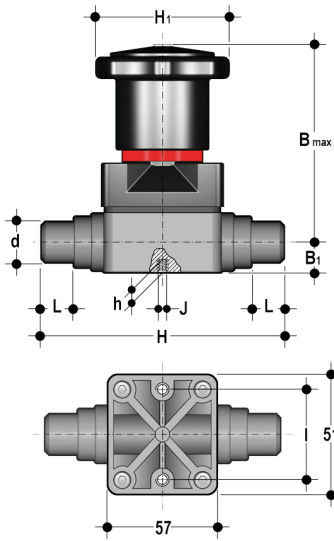

CMDM

Compact diaphragm valve with male ends for socket welding, metric series

d	DN	PN	B _{max}	B ₁	H	H ₁	h	l	J	L	g	EPDM code	FKM code	PTFE code
20	15	6	86	15	124	59	8	35	M5	17	270	CMDM020E	CMDM020F	CMDM020P

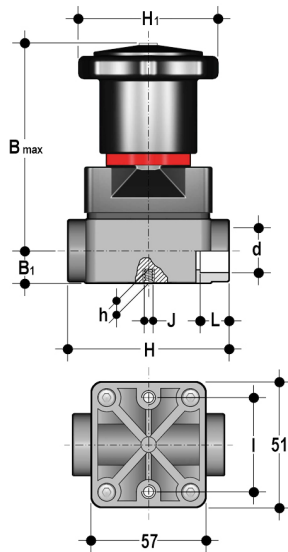

CMIM

Compact diaphragm valve with female ends for socket welding, metric series

d	DN	PN	B _{max}	B ₁	H	H ₁	h	l	J	L	g	EPDM code	FKM code	PTFE code
16	12	6	86	15	75	59	8	35	M5	14	240	CMIM016E	CMIM016F	CMIM016P
20	15	6	86	15	75	59	8	35	M5	16	240	CMIM020E	CMIM020F	CMIM020P

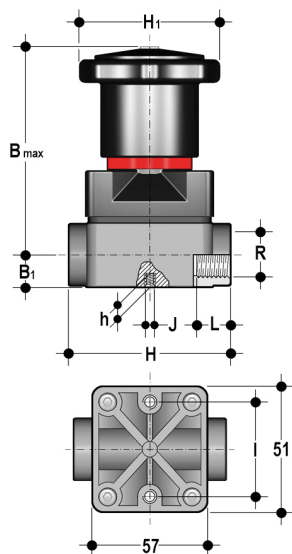

CMFM

Compact diaphragm valve with BSP threaded female ends

R	DN	PN	B _{max}	B ₁	H	H ₁	h	I	J	L	g	EPDM code	FKM code	PTFE code
3/8"	12	6	86	15	75	59	8	35	M5	12	240	CMFM038E	CMFM038F	CMFM038P
1/2"	15	6	86	15	75	59	8	35	M5	15	240	CMFM012E	CMFM012F	CMFM012P

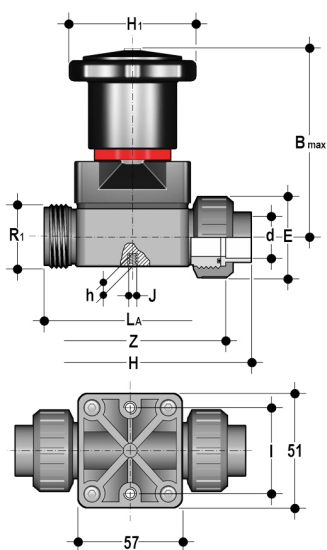

CMUIM

Compact diaphragm valve with female union ends for socket welding, metric series

d	DN	PN	B _{max}	E	H	H ₁	h	I	J	LA	R ₁	Z	g	EPDM code	FKM code	*PTFE code
20	15	6	86	47,5	130	59	8	35	M5	90	1"	98	255	CMUIM020E	CMUIM020F	CMUIM020P

COMPONENTS

EXPLODED VIEW

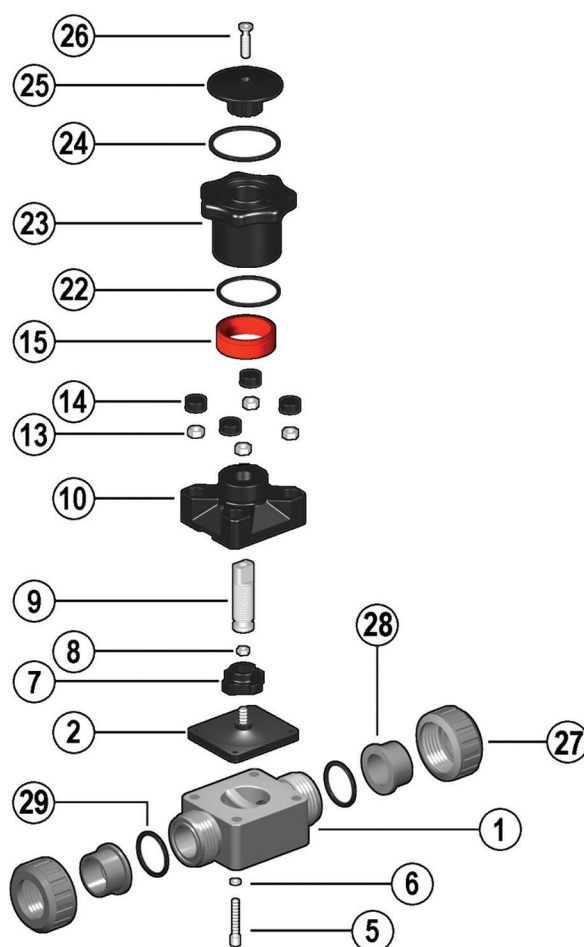

- | | | |
|--|---|---|
| 1 Body (PP-H - 1) | 8 Nut (STAINLESS steel - 1) | 22 O-Ring (NBR - 1) |
| 2 Diaphragm seal (EPDM, FKM, PTFE - 1) | 9 Stem (STAINLESS steel - 1) | 23 Handwheel (PA-GR - 1) |
| 5 Fastening screw (STAINLESS steel - 4) | 10 Bonnet (PA-GR - 1) | 24 O-Ring (NBR - 1) |
| 6 Washer (STAINLESS steel - 4) | 13 Nut (STAINLESS steel - 4) | 25 Bonnet (PA-GR - 1) |
| 7 Shutter (PA-GR - 1) | 14 Protection plug (POM - 4) | 26 Fastening screw (STAINLESS steel - 1) |
| | 15 Optical position indicator (PVDF - 1) | |

The material of the component and the quantity supplied are indicated between brackets

DISASSEMBLY

If the valve is already installed on the line, shut-off the fluid flow upstream and make sure that there is no pressure. If necessary, fully drain the system downstream. If there are hazardous fluids present, drain and ventilate the valve.

The diaphragm constitutes the part of the valve more subject to mechanical and chemical stress from the fluid. Consequently, the condition of the diaphragm must be checked at regular intervals in accordance with the service conditions. To do this, it must be

disconnected from the handwheel and from the valve body.

- 1) Unscrew the four screws (5) and separate the body (1) from the internal components.
- 2) Unscrew the diaphragm seal (2) from the shutter (7).
- 3) If necessary, clean or replace the diaphragm seal (2).
- 4) If necessary, lubricate the stem (9).

ASSEMBLY

- 1) The diaphragm seal (2) must be screwed fully into the compressor (7) in a clockwise direction. If necessary, unscrew slightly in an anticlockwise direction to line up the screw holes.
- 2) Fix the bonnet (10) to the body (1) using screws (5). Tighten the screws, making sure not to over-compress the diaphragm.

INSTALLATION

The valve can be installed in any position and in any direction. When starting up the plant, make sure that there are no leaks from between the diaphragm and the valve body. If necessary, tighten the fastening screws (5).

SETTING

The valve is factory set to guarantee a permanent seal without requiring any further intervention. To adjust the setting, rotate the handwheel to the required minimum opening position, remove screw (26) using a hex key. Remove the bonnet (25) and rotate the handwheel (23) clockwise until a resistance to the rotation is felt.

If necessary, replace the O-Ring (24) in its seating and re-insert the bonnet (25) in the handwheel: the double D connection must fit over the stem (9) and, with a slight twisting action, align the ribs in the bonnet with those in the handwheel.

Tighten screw (26) to a sufficiently high torque value.

Each turn of the handwheel corresponds to 1.75mm travel.