

 *Aliaxis*



**VM DN 8**

PVC-U

Mini Diaphragm valve

# VM DN 8

The VM mini-valve is used to shut-off and regulate fluid flow and is characterised by its reduced size.

## MINI DIAPHRAGM VALVE

- Connection system for solvent weld and threaded joints
- **Extremely compact dimensions**
- **Can be installed in any position**
- **Valve material compatibility** (PVC-U) and elastomer seal elements (EPDM), with water, drinking water and other food substances as per **current regulations**
- Specifically designed for laboratory applications or for sampling purposes

| Technical specifications   |  |
|----------------------------|--|
| <b>Construction</b>        | Mini-diaphragm valve   |
| <b>Size range</b>          | DN 8 (1/4")  |
| <b>Nominal pressure</b>    | PN 10 with water at 20 °C  |
| <b>Temperature range</b>   | 0 °C ÷ 60 °C   |
| <b>Coupling standards</b>  | <b>Solvent welding:</b> EN ISO 1452, EN ISO 15493 Can be coupled to pipes according to EN ISO 1452, EN ISO 15493.<br><b>Thread:</b> ISO 228-1, DIN 2999                                |
| <b>Reference standards</b> | <b>Construction criteria:</b> EN ISO 16138, EN ISO 1452, EN ISO 15493<br><b>Test methods and requirements:</b> ISO 9393<br><b>Installation criteria:</b> DVS 2204, DVS 2221, UNI 11242 |
| <b>Valve material</b>      | PVC-U  |
| <b>Seal material</b>       | EPDM   |
| <b>Control options</b>     | Manual control   |

# DIMENSIONS

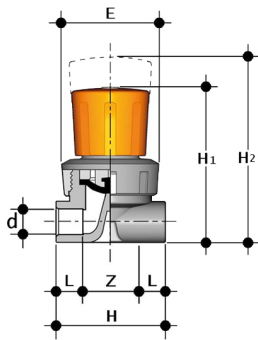

## VMIV

Mini-diaphragm valve with female ends for solvent welding, metric series

| d  | DN | PN | E  | H  | H <sub>1</sub> | H <sub>2</sub> | L  | Z  | g  | Code     |
|----|----|----|----|----|----------------|----------------|----|----|----|----------|
| 12 | 8  | 10 | 43 | 48 | 72             | 81             | 12 | 24 | 70 | VMIV012E |

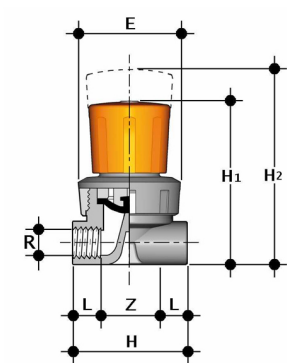

## VMFV

Mini-diaphragm valve with BSP threaded female ends

| R    | DN | PN | E  | H  | H <sub>1</sub> | H <sub>2</sub> | L    | Z  | g  | Code     |
|------|----|----|----|----|----------------|----------------|------|----|----|----------|
| 1/4" | 8  | 10 | 43 | 48 | 72             | 81             | 10,5 | 27 | 70 | VMFV014E |

# COMPONENTS

## EXPLODED VIEW

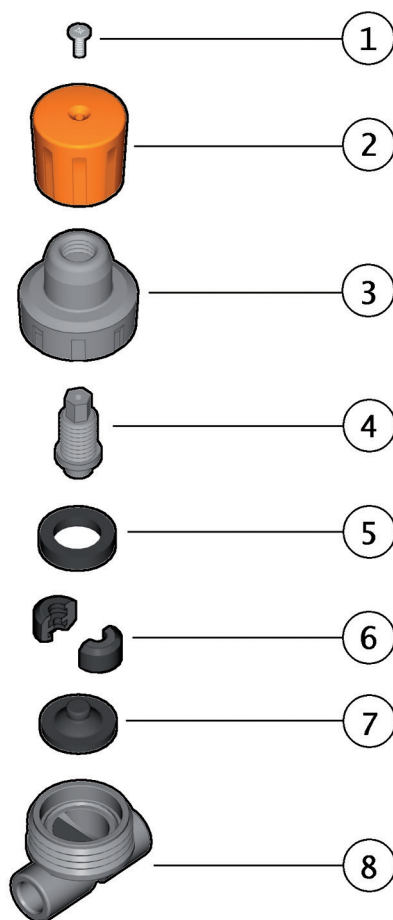

**1** Screw (STAINLESS steel - 1)

**2** Handwheel (PVC-U - 1)

**3** Bonnet (PVC-U - 1)

**4** Stem (PVC-U - 1)

**5** Sleeve (POM - 1)

**6** Split couplings (POM - 2)

**7** Diaphragm (EPDM- 1)

**8** Body (PVC-U - 1)

The material of the component and the quantity supplied are indicated between brackets

## DISASSEMBLY

- 1) Isolate the mini-valve from the fluid.
- 2) Unscrew the bonnet (3) clockwise.
- 3) Unscrew screw (1) and remove the handwheel (2).
- 4) Remove the stem (4) to access the split couplings (6), the sleeve (5) and diaphragm (7)

## ASSEMBLY

- 1) Assemble the two split couplings (6), the sleeve (5) and diaphragm (7) to the stem (4), making sure that the latter is inserted in the larger cavity of each half collar, while the diaphragm connection is inserted in the smaller cavity
- 2) Screw the stem (4) to the bonnet (3)
- 3) Position the handwheel (2) on the bonnet and tighten the screw (1)
- 4) Screw the bonnet to the body (8)



**Note:** during assembly operations, it is advisable to lubricate the rubber seals. Mineral oils are not recommended for this task as they react aggressively with EPDM rubber.

# INSTALLATION

The mini-valve can be installed in any position. If the valve is installed in a vertical position, if the connection is solvent welded, make sure that the solvent cement does not enter inside the body, as this would damage the seating of the seal.