

 *Aliaxis*



VR DN 15÷80

PP-H

Check valve

VR DN 15÷80

The VR is an angle seat check valve with weighted PP-H piston that allows the passage of fluid in one direction only.

CHECK VALVE

- Connection system for weld, threaded and flanged joints
- **No metal parts in contact with the fluid**
- **Piston with counterweight** able to work with high intensity fluid
- Limited pressure drop. Only minimum back pressure is required for the hermetic seal
- **Valve material compatibility** (PP-H) with water conveyance, drinking water and other food substances according to **current regulations**
- Can be maintained with the valve body installed

Technical specifications	
Construction	Angle seat check valve
Size range	DN 15 ÷ 80
Nominal pressure	DN 10÷50: PN 10 with water at 20° C DN 65 PN 6 with water at 20° C DN 80: PN 4 with water at 20° C
Temperature range	0 °C ÷ 100 °C
Coupling standards	Welding: EN ISO 15494. Can be coupled to pipes according to EN ISO 15494 Thread: ISO 228-1, DIN 2999 Flanging system: ISO 7005-1, EN 1092-1, EN ISO 15494, EN 558-1, DIN 2501, ANSI B.16.5 cl. 150
Reference standards	Construction criteria: EN ISO 16137, EN ISO 15494 Test methods and requirements: ISO 9393 Installation criteria: DVS 2202-1, DVS 2207-11, DVS 2208-1, UNI 11318
Valve material	PP-H
Seal material	EPDM or FKM

TECHNICAL DATA

PRESSURE VARIATION ACCORDING TO TEMPERATURE

For water and non-hazardous fluids with regard to which the material is classified as CHEMICALLY RESISTANT. In other cases, a reduction of the nominal pressure PN is required (25 years with safety factor).

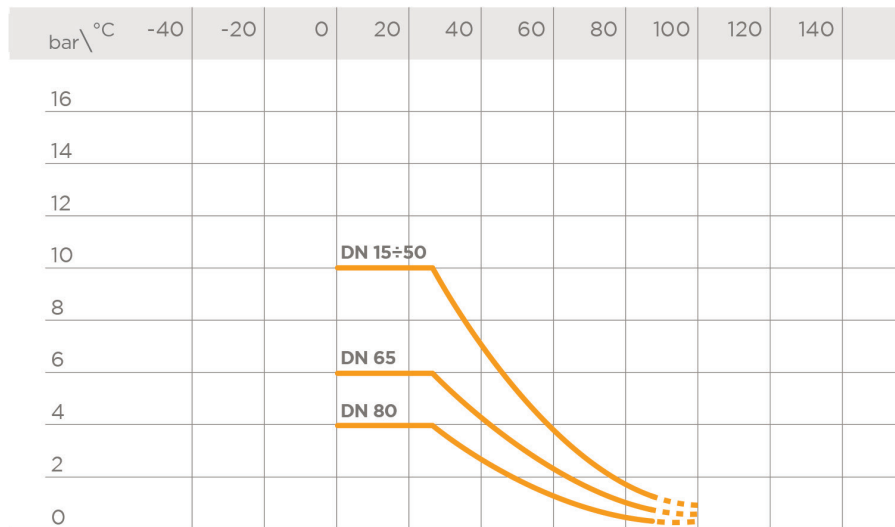

PRESSURE DROP GRAPH

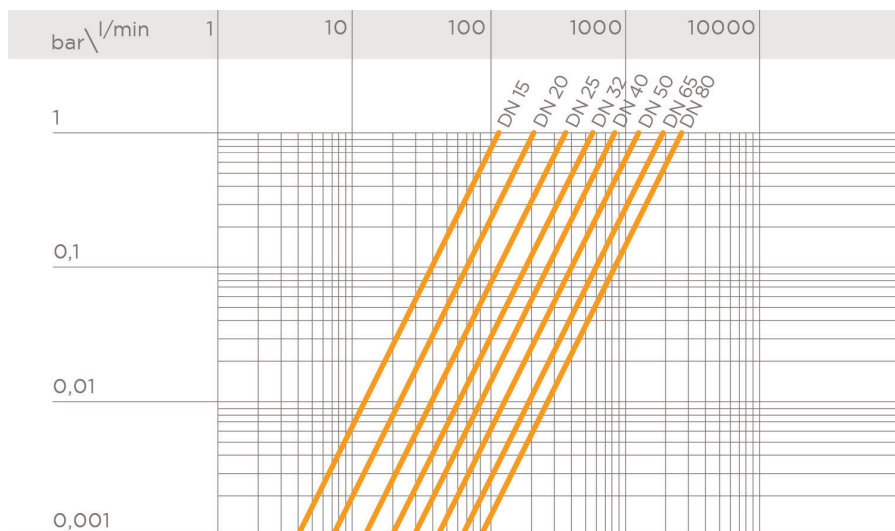

K_v100 FLOW COEFFICIENT

The K_v100 flow coefficient is the Q flow rate of litres per minute of water at a temperature of 20°C that will generate Δp= 1 bar pressure drop at a certain valve position. The K_v100 values shown in the table are calculated with the valve completely open.

DN	15	20	25	32	40	50	65	80
K _v 100 l/min	110	205	375	560	835	1300	1950	2600

MINIMUM PRESSURE REQUIRED TO LIFT THE PISTON

DN	15	20	25	32	40	50	65	80
bar	0,008	0,009	0,014	0,017	0,018	0,021	0,022	0,022

MINIMUM SEALING PRESSURE (PISTON IN CLOSED POSITION)

DN	15	20	25	32	40	50	65	80
mm H ₂ O	150	200	350	350	350	350	350	350

The figures refer to the seals that are not worn.

The information in this leaflet is provided in good faith. No liability will be accepted concerning technical data that is not directly covered by recognised international standards. FIP reserves the right to carry out any modification. Products must be installed and maintained by qualified personnel.

DIMENSIONS

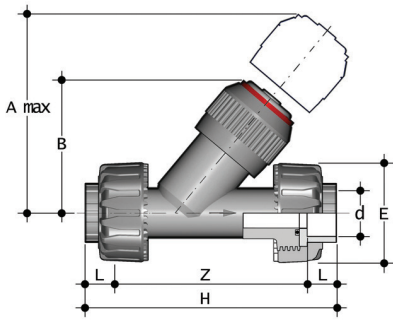

VRUIM

Check valve with female union ends for socket welding, metric series

d	DN	PN	A max	B	E	H	Z	g	EPDM code	FKM code
20	15	10	125	71	55	138	109	165	VRUIM020E	VRUIM020F
25	20	10	145	83	66	157	125	227	VRUIM025E	VRUIM025F
32	25	10	165	94	74	179	143	380	VRUIM032E	VRUIM032F
40	32	10	190	109	86	205	164	645	VRUIM040E	VRUIM040F
50	40	10	210	119	99	244	197	915	VRUIM050E	VRUIM050F
63	50	10	240	143	120	294	239	1555	VRUIM063E	VRUIM063F

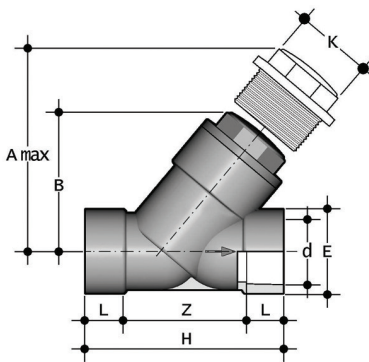

VRIM

Check valve with female ends for socket welding, metric series

d	DN	PN	A max	B	E	H	K	Z	g	EPDM code	FKM code
75	65	6	300	176	103	241	96	179	2450	VRIM075E	VRIM075F
90	80	4	325	192	115	260	105	189	3130	VRIM090E	VRIM090F

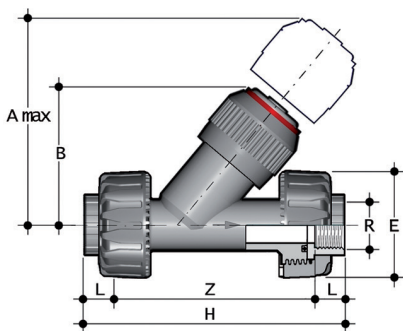

VRUFM

Check valve with BSP threaded female union ends

R	DN	PN	A max	B	E	H	Z	g	EPDM code	FKM code
1/2"	15	10	125	71	55	143	113	165	VRUFM012E	VRUFM012F
3/4"	20	10	145	83	65	160	127	227	VRUFM034E	VRUFM034F
1"	25	10	165	94	74	183	145	380	VRUFM100E	VRUFM100F
1" 1/4	32	10	190	109	86	214	171	645	VRUFM114E	VRUFM114F
1" 1/2	40	10	210	119	99	235	192	915	VRUFM112E	VRUFM112F
2"	50	10	240	143	120	285	234	1555	VRUFM200E	VRUFM200F

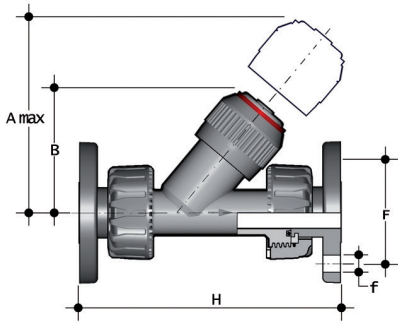

VRUOM

Check valve with union ends and fixed flanges, drilled EN/ISO/DIN PN10/16

d	DN	PN	A max	B	F	f	H	g	EPDM code	FKM code
20	15	10	125	72	65	14	163	265	VRUOM020E	VRUOM020F
25	20	10	145	84	75	14	193	327	VRUOM025E	VRUOM025F
32	25	10	165	95	85	14	211	480	VRUOM032E	VRUOM032F
40	32	10	190	111	100	18	244	795	VRUOM040E	VRUOM040F
50	40	10	210	120	110	18	277	1065	VRUOM050E	VRUOM050F
63	50	10	240	139	125	18	331	1705	VRUOM063E	VRUOM063F

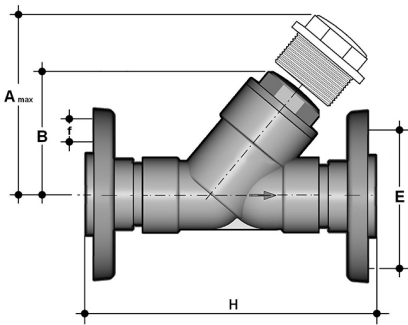

VROM

Check valve with steel core backing ring, PP/FRP coated, drilled EN/ISO/DIN PN10/16

d	DN	PN	A max	B	F	f	H	g	EPDM code	FKM code
75	65	6	300	179	145	18	356	5990	VROM075E	VROM075F
90	80	4	325	192	160	18	404	7230	VROM090E	VROM090F

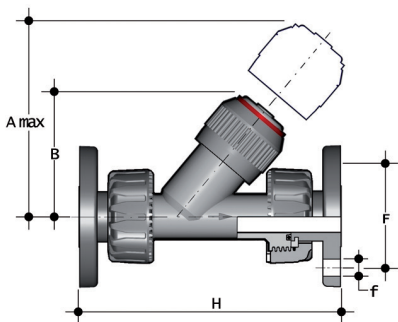

VRUOAM

Check valve with union ends and fixed flanges, drilled ANSI B16.5 cl.150 #FF

Size	DN	PN	A max	B	F	f	H	g	EPDM code	FKM code
1/2"	15	10	125	72	60	16	175	265	VRUOAM012E	VRUOAM012F
3/4"	20	10	145	84	70	16	214	327	VRUOAM034E	VRUOAM034F
1"	25	10	165	95	79	16	237	480	VRUOAM100E	VRUOAM100F
1 1/4"	32	10	190	111	89	16	253	795	VRUOAM114E	VRUOAM114F
1 1/2"	40	10	210	120	98	16	289	1065	VRUOAM112E	VRUOAM112F
2"	50	10	240	139	121	19	333	1705	VRUOAM200E	VRUOAM200F

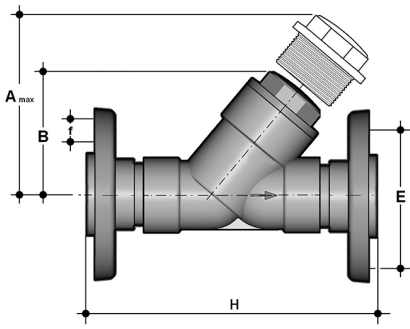

VROAM

Check valve with steel core backing ring, PP/FRP coated, drilled ANSI B16.5 cl.150 #FF

d - Size	DN	PN	A max	B	F	f	H	g	EPDM code	FKM code
75 - 2"1/2	65	6	300	176	139,7	18	356	5595	VROAM075E	VROAM075F
90 - 3"	80	4	325	192	152,4	18	404	6385	VROAM090E	VROAM090F

COMPONENTS

EXPLODED VIEW

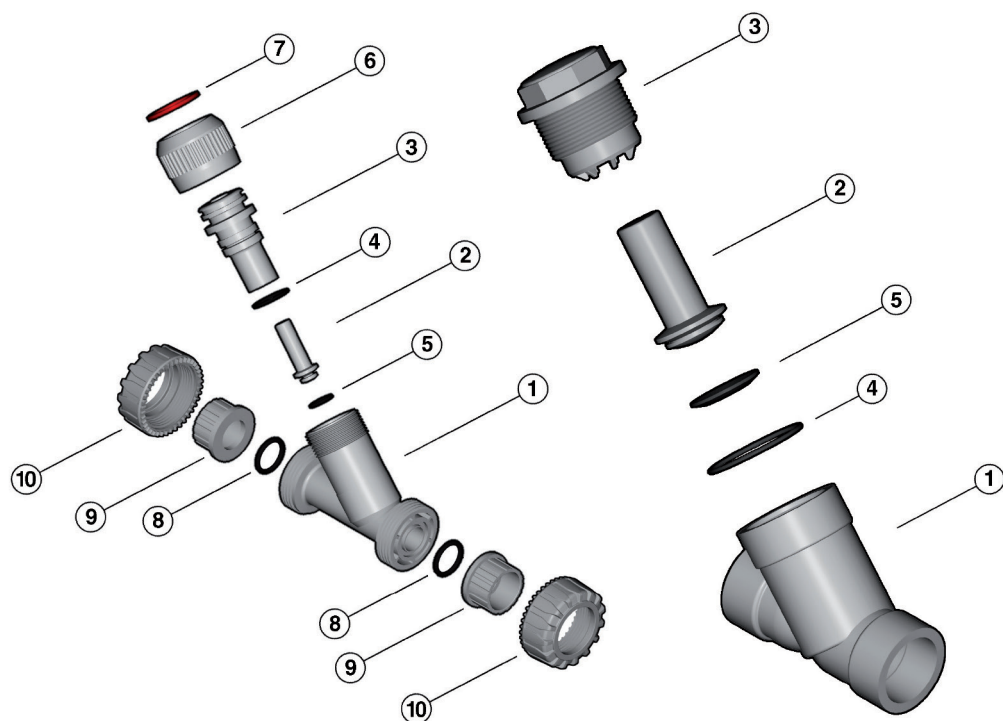

DN 15÷50

DN 65÷80

- | | | |
|--------------------------------------|---|--|
| 1 Body (PP-H - 1) | 5 Piston flat gasket (EPDM o FKM - 1)* | 8 Socket seal O-Ring (EPDM or FKM - 2)* |
| 2 Piston (PP-H - 1) | 6 Union nut (PP-H - 1) | 9 End connector (PP-H - 2)* |
| 3 Bonnet (PP-H - 1) | 7 Retaining ring (PP-H - 1) | 10 Union nut (PP-H - 2) |
| 4 O-Ring (EPDM or FKM - 1/2)* | | |

* Spare parts

The material of the component and the quantity supplied are indicated between brackets

DISASSEMBLY

DN 15÷50 (FIG.A)

- 1) Isolate the valve from the fluid flow.
- 2) Unscrew the union nut (6) and separate the bonnet (3) from the body (1).
- 3) Remove the piston (2) and flat gasket (5).
- 4) Remove the retaining ring (7) and separate the union nut (6) from the bonnet (3).
- 5) Remove the O-Ring from the bonnet (4).

DN 65÷80 (FIG. B)

- 1) Isolate the valve from the fluid flow.
- 2) Unscrew the bonnet (3) from the body (1).
- 3) Remove the O-Ring (4) from its seating in the body (1).
- 4) Remove the piston (2) and relative flat gasket (5).

ASSEMBLY

DN 15÷50 (FIG. A)

- 1) Insert the O-Ring (4) in its seating in the bonnet (3).
- 2) Insert the bonnet (3) in union nut (6) and fix the two components using the retaining ring (7).
- 3) Insert the piston (2) complete with flat gasket (5) in the bonnet (3), then fit the bonnet on the body (1).
- 4) Screw the union nut (6) on the body (1).

DN 65÷80 (FIG. B)

- 1) Insert the piston (2) complete with flat gasket (5) in the bonnet (3).
- 2) Insert the O-ring (4) in the body (1) seating.
- 3) Screw the bonnet (3) to the body (1)



Note: maintenance operations can be carried out with the valve body installed during assembly, it is advisable to lubricate the rubber seals. Mineral oils are not recommended for this task as they react aggressively with EPDM rubber.

Fig. A

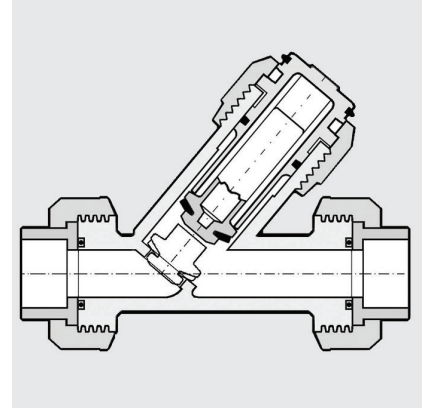
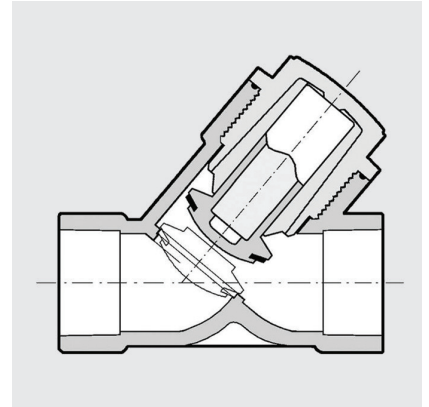

Fig. B



INSTALLATION

The check valve can be installed on vertical or horizontal axis pipes. The bonnet (3) must however always be turned upwards as the piston works by gravity.

If the valve is installed in a vertical position, if the connection is solvent welded, make sure that the solvent cement does not enter inside the body, as this would damage the seating of the seal.

Install the valve such that the arrow stamped on the body indicates the direction of fluid flow .

WARNINGS

Do not use compressed air or other gases to test thermoplastic lines.