



VXE/CE - VXE/CP DN 65÷100

PVC-U/PVC-C

ELECTRICALLY OR PNEUMATICALLY ACTUATED
TWO-WAY EASYFIT BALL VALVE



VXE/CE – VXE/CP

DN 65÷100

FIP and Giugiaro Design designed and developed VXE Easyfit, the innovative True Union ball valve with union nut tightening control system that permits simple and safe installation for reliable service in time.



ELECTRICALLY OR PNEUMATICALLY ACTUATED TWO-WAY EASYFIT BALL VALVE

- Connection system using solvent welded and threaded joints
- **Patented Easyfit system:** innovative mechanism based on the multifunctional handle quick release mechanism that permits union nut rotation during valve installation and ball seat carrier adjustment
- **Valve material compatibility** (U PVC-C) and **elastomer seal elements** (EPDM or FKM), with water, drinking water and other food substances as per current regulations
- Easy radial dismounting allowing quick replacement of O-rings and ball seats without any need for tools
- **PN16 radial dismounting valve body** (True Union) made for PVC-C injection moulding and European Directive 2014/68/EC compliant for PED pressurised equipment. ISO 9393 compliant test requirements. Maximum fluid pressure for valve operation 6 bar.
- Valve body with built in anchoring frame for the special **Power Quick module** dedicated to accessory or pneumatic and electric actuator installation
- Option of disassembling downstream pipes with the valve in the closed position
- Floating **full bore ball** with high surface finish made in CNC work stations to achieve precise dimensional tolerance and high surface finish.

Technical specifications - VXE	
Construction	Easyfit 2-way True Union ball valve with locked carrier
Size range	DN 65 ÷ 100
Nominal pressure	PVC-U: PN 16 with water at 20° C PVC-C: PN16 with water at 20° C
Temperature range	PVC-U: 0 °C ÷ 60 °C PVC-C: 0° C ÷ 100° C
PVC-U coupling standards	Solvent welding: EN ISO 1452, EN ISO 15493, BS 4346-1, DIN 8063, NF T54-028, ASTM D 2467, JIS K 6743. Can be coupled to pipes according to EN ISO 1452, EN ISO 15493, DIN 8062, NF T54-016, ASTM D 1785, JIS K 6741. Thread: ISO 228-1, DIN 2999, ASTM D 2464, JIS B 0203.
PVC-C coupling standards	Solvent welding: EN ISO 15493, ASTM F 439. Can be coupled to pipes according to EN ISO 15493, ASTM F 441 Thread: ISO 228-1, DIN 2999, ASTM F 437 Flanging system: ISO 7005-1, EN ISO 15493, EN 558-1, DIN 2501, ANSI B.16.5 cl. 150, JIS B 2220.
Reference standards	PVC-U construction criteria: EN ISO 16135, EN ISO 1452, EN ISO 15493 PVC-C construction criteria: EN ISO 16135, EN ISO 15493 Test methods and requirements: ISO 9393 PVC-U/PVC-C installation criteria: DVS 2204, DVS 2221, UNI 11242 Actuator couplings: ISO 5211
Valve material	PVC-U / PVC-C
Seal material	EPDM, FKM (standard size O-Rings); PTFE (ball seats)
Control options	Electric actuator; pneumatic actuator

In addition to the manually actuated version, VXE is also available in VXE/CE electrically actuated and VXE/CP pneumatically actuated configurations. Actuators are firmly connected to the valve by the special FIP Power Quick modules fully made of PP-GR technopolymer. VXE/CE and VXE/CP are constructed with actuators meeting current regulations and selected by FIP according to their quality and reliability requirements. The efficiency of these valves, tested according to the company's quality standards, is guaranteed by the expertise and know-how that FIP dedicates to manufacturing its products.

Technical specifications - Electric actuator	
Reference standards	<p>Construction criteria: Electromagnetic compatibility EMC 2004/108/CE. Low voltage directive 2006/95/CE. Machinery directive 2006/42/CE. R.O.H.S. directive 2011/65/CE</p> <p>Coupling for valves: ISO 5211; DIN 3337</p>
Actuator material	<p>Plastic parts: PA6,6 FV 30% and Nylon. Metallic parts: 304L stainless steel or steel + tin-plating</p>
Supply Voltage	<p>12V DC* - 24V AC/DC - 90-240V AC - 400V three phase* *voltages available upon request</p>
Temperature range	<p>From -10 °C to +55 °C</p>
Standard equipment	<ul style="list-style-type: none"> • Manual safety override • Visual position indicator • Two auxiliary limit switches (5A) adjustable FC1, FC2 • Polyswitch torque limiter • Anti-condensation heating element (12V DC)
Accessories	<ul style="list-style-type: none"> • Positioner board 4-20 mA or 0-10V DC • Fail Safe unit • Anti-condensation heating element • Feedback potentiometer 100 - 1000 - 5000 - 10000 Ohm • 4-20 mA position transmitter • Kit with additional pair of auxiliary limit switches
Special versions upon request	<ul style="list-style-type: none"> • CEI34 50% service • Protection class IP68 or ATEX II 2 GD EEx d IIB T6 • Different operating times
Electrical connection	<ul style="list-style-type: none"> • Power supply: DIN 43650 connector 3P + GND • Limit switch: Cable gland ISO M20

Technical specifications - Pneumatic actuator	
Reference standards	<p>Construction criteria: Machinery directive 2006/42/CE R.O.H.S. directive 2011/65/CE EN 15714-3</p> <p>Coupling for valves: ISO 5211, DIN 3337</p> <p>Compressed air connections: NAMUR VDI\VDE-3845</p> <p>Top connections for accessories: NAMUR VDI\VDE-3845</p>
Actuator material	<p>Body: hard coat anodised extruded aluminium. IP67 Bonnet: polyester powder painted aluminium alloy Pinion: nickel-plated carbon steel Other materials available upon request</p>
Control air pressure	<p>From 5 to 8 bar. Pmax= 10 bar Reduced control pressure executions available upon request</p>
Power supply	<p>Dry or lubricated filtered compressed air. If using other fluids, contact the FIP service centre</p>
Temperature range	<p>From -20 °C to +80 °C</p>
Accessories	<ul style="list-style-type: none"> • Optical position indicator • LSQT electromechanical and PNP inductive limit switch boxes (Namur upon request) • Electric-pneumatic positioner 4-20 mA • 3-5/2 way pilot solenoid valves

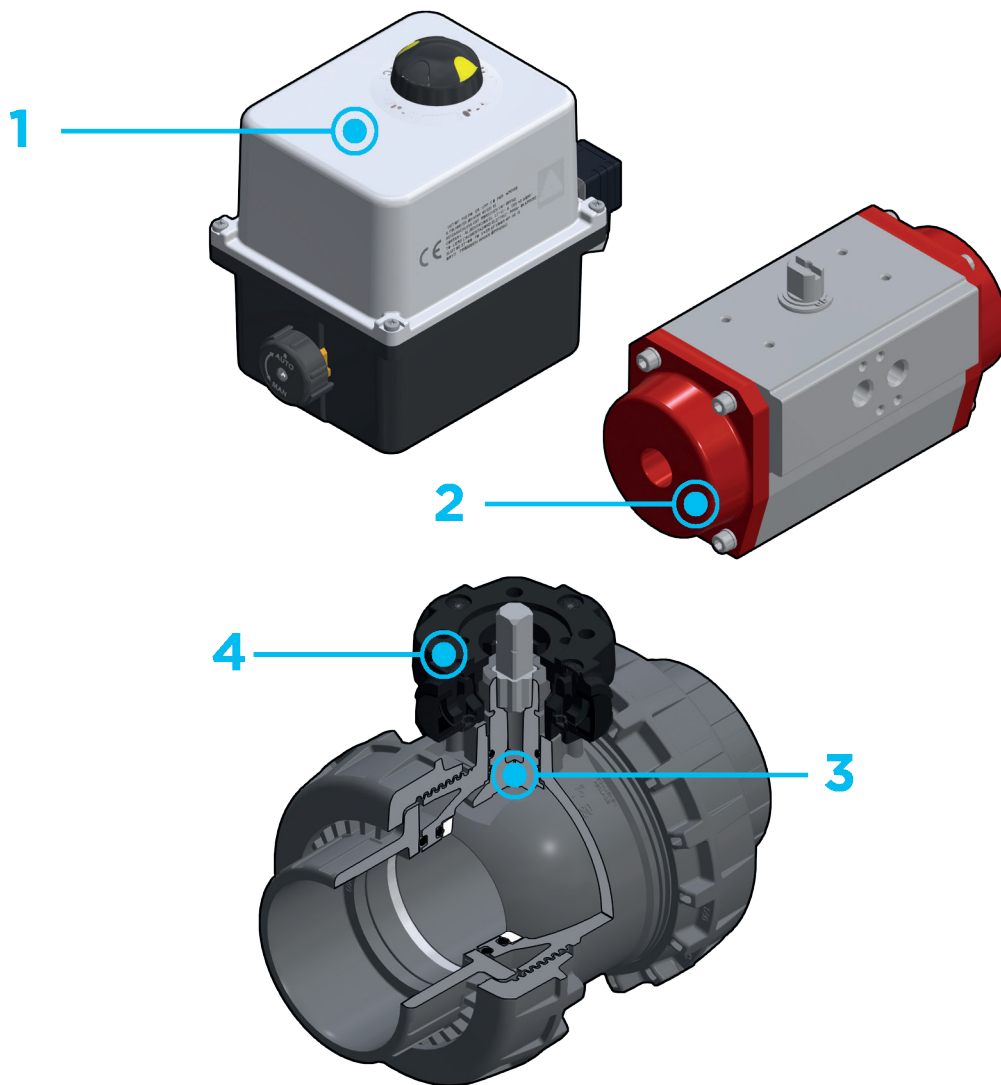

1 Electric actuator constructed according to FIP specifications; with plastic shell and standard emergency override. Available with voltages from 12 to 240V.

2 Rack & pinion type pneumatic actuator constructed according to FIP specifications: fully protected against weather corrosion

available in double-acting (DA) or simple-acting normally closed (NC) or normally open (NO) versions.

3 Stem with high surface finish and **double O-Ring and PTFE anti-friction disk** that limits friction to a minimum and grants excellent operating torque.

4 Easy to install **Easyfit PowerQuick** module for pneumatic or electric actuator fully made of highly robust technopolymer.

TECHNICAL DATA

PRESSURE VARIATION ACCORDING TO TEMPERATURE

PVC-U BODY

For water and non-hazardous fluids with regard to which the material is classified as CHEMICALLY RESISTANT. In other cases, a reduction of the nominal pressure PN is required (25 years with safety factor).



PVC-C BODY



PRESSURE DROP GRAPH

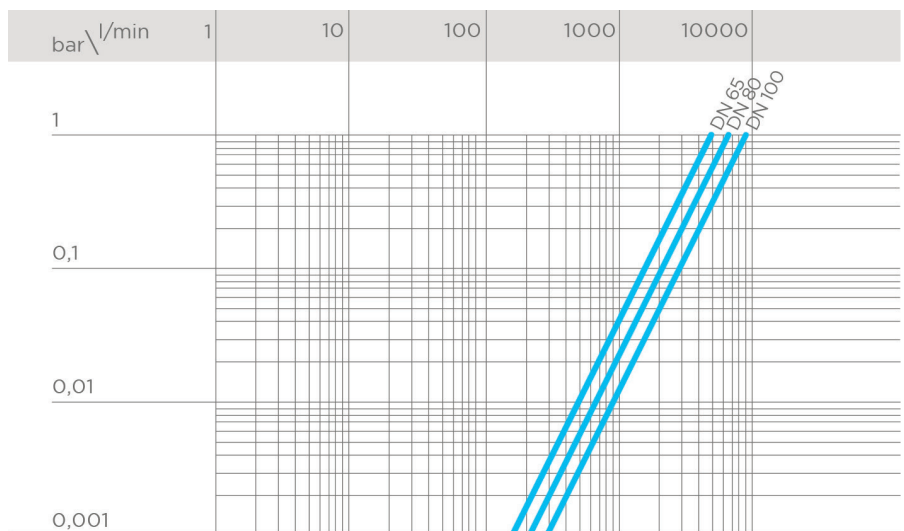

K_v100 FLOW COEFFICIENT

The K_v100 flow coefficient is the Q flow of litres per minute of water at a temperature of 20°C that will generate Δp= 1 bar pressure drop at a certain valve position.

The K_v100 values shown in the table are calculated with the valve completely open.

DN	65	80	100
Kv100 l/min	5000	7000	9400

ELECTRIC ACTUATOR DATA

DN 65 FUNCTIONAL CHARACTERISTICS

Characteristics	DC	AC/DC	AC
Power supply	*12V	24V	90±240V
Power	15W	15W	15W
Max operating time	11 s	12 s	13 s
IEC34 service	50%	30%	30%
Protection class	IP66	IP65	IP65
Frequency	-	50/60 Hz	50/60 Hz

DN 80 FUNCTIONAL CHARACTERISTICS

Characteristics	DC	AC/DC	AC
Power supply	*12V	24V	90±240V
Power	45W	45W	45W
Max operating time	11 s	12 s	13 s
IEC34 service	50%	30%	30%
Protection class	IP66	IP65	IP65
Frequency	-	50/60 Hz	50/60 Hz

DN 100 FUNCTIONAL CHARACTERISTICS

Characteristics	DC	AC/DC	AC
Power supply	*12V	24V	90±240V
Power	45W	45W	45W
Max operating time	12 s	13 s	15 s
IEC34 service	50%	30%	30%
Protection class	IP66	IP65	IP65
Frequency	-	50/60 Hz	50/60 Hz

*Upon request

POWER CONNECTION DIAGRAM

- 1 Shared
- 2 Open
- 3 Closed

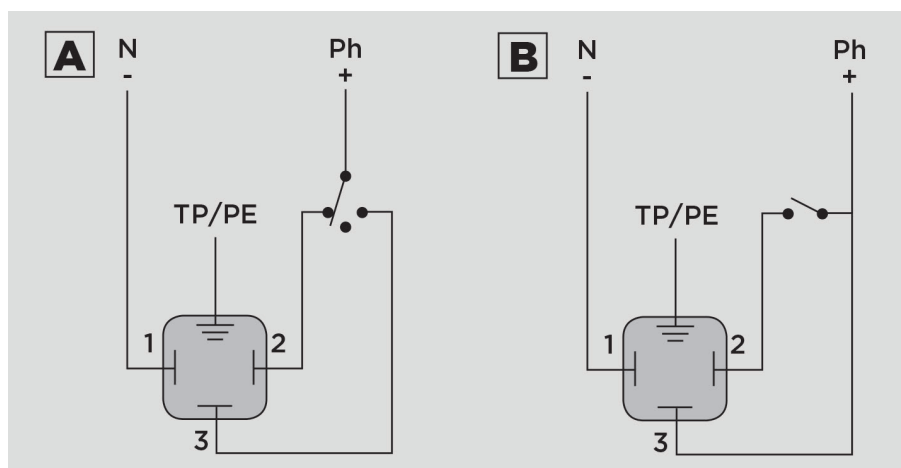

AUXILIARY LIMIT SWITCH CONNECTION DIAGRAM

FC1 Open auxiliary limit switch
FC2 Close auxiliary limit switch

- 4** Shared FC1
- 5** Open FC1
- 6** Shared FC2
- 7** Open FC2
- 8** Close FC1
- 9** Close FC2

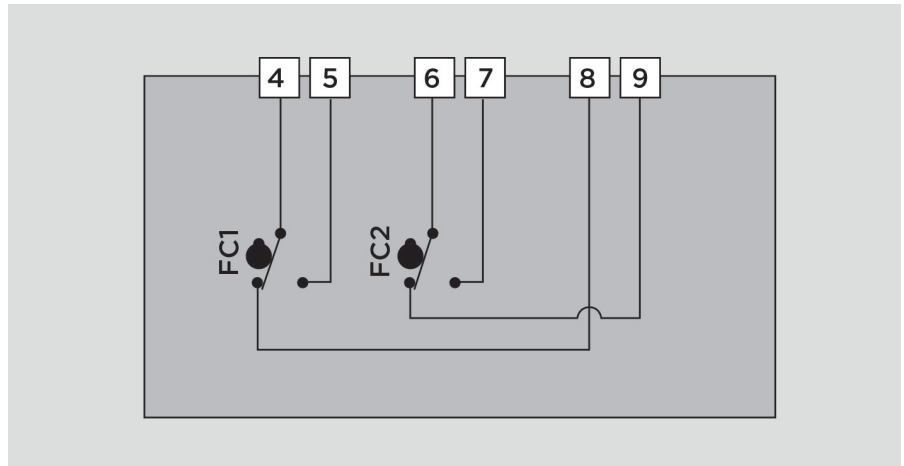

PNEUMATIC ACTUATOR DATA

FUNCTIONAL CHARACTERISTICS

Function type	double-acting	Normally closed (NC)	Normally Open (NO)
Valve opening	air	air	spring
Valve closing	air	spring	air

ACTUATOR CAPACITY

L: litre, equivalent to 10^{-3} m^3

Air consumption in normal litres (or normal cubic metres) per operating cycle can be calculated by correcting according to operating conditions such as control air pressure.

DN	65	80	100
DA	0.45 L	0.45 L	0.61 L
SA (NC-NO)	0.244 L	0.244 L	0.244 L

COMPRESSED AIR CONNECTIONS

Function type	Double-acting (DA)	Normally closed (NC)	Normally Open (NO)
Valve opening	Inlet A	Inlet A	-
Valve closing	Inlet B	-	Inlet A

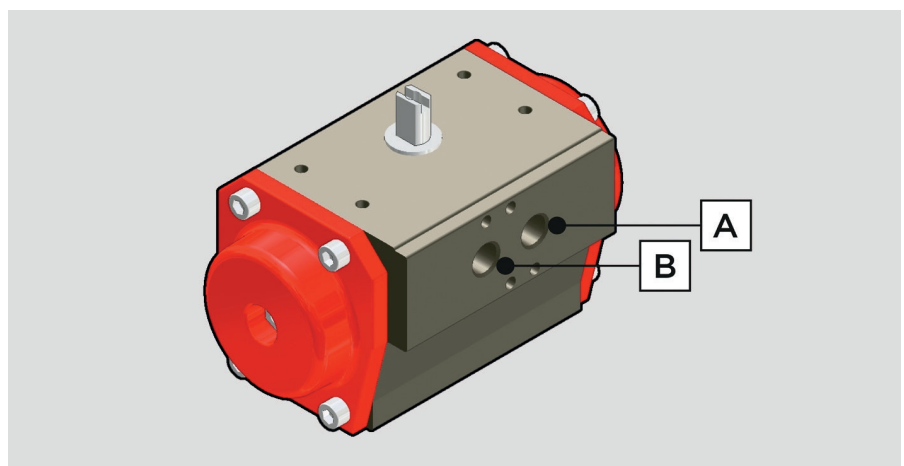

DIMENSIONS

VXE/CE DN 65÷100 PVC-U

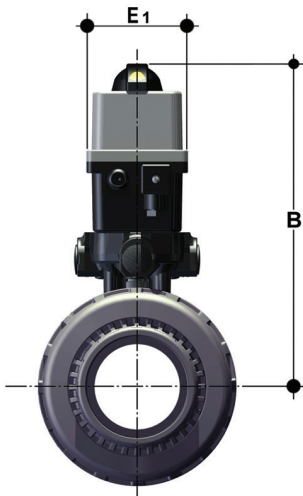

Dimensions common to all versions

DN	B	E1
65	281	92
80	312	128
100	332	128

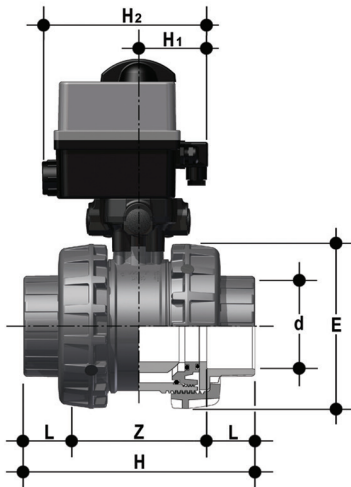

VXEIV/CE 90-240 V AC

2 way Easyfit valve with female ends for solvent welding, metric series with multi-volt electric actuator 90-240 V AC 50-60 Hz

d	DN	*PN	E	H	L	Z	H ₁	H ₂	g	EPDM Code	FKM Code
75	65	6	157	211	44	123	82	187	3750	VXEIVEM075E	VXEIVEM075F
90	80	6	174	248	51	146	93	202	6232	VXEIVEM090E	VXEIVEM090F
110	100	6	212	283	61	161	93	202	8614	VXEIVEM110E	VXEIVEM110F

* PN10 upon request

DIMENSIONS

VXE/CE DN 65÷100 PVC-U

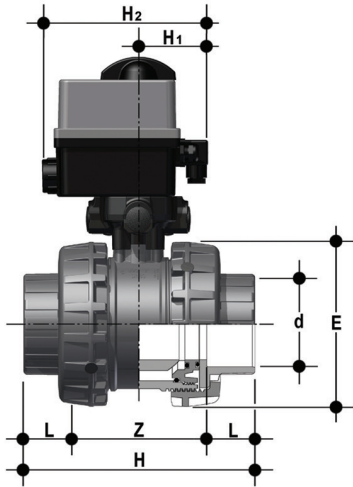

VXEIV/CE 24 V AC/DC

2 way Easyfit valve with female ends for solvent welding, metric series with electric actuator
24 V AC/DC

d	DN	*PN	E	H	L	Z	H ₁	H ₂	g	EPDM Code	FKM Code
75	65	6	157	211	44	123	82	187	3750	VXEIVEL075E	VXEIVEL075F
90	80	6	174	248	51	146	93	202	6232	VXEIVEL090E	VXEIVEL090F
110	100	6	212	283	61	161	93	202	8614	VXEIVEL110E	VXEIVEL110F

* PN10 upon request

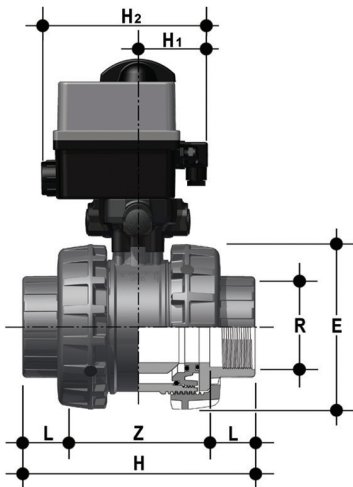

VXEFV/CE 90-240 V AC

2 way Easyfit valve with female ends, gas cylinder thread with multi-volt electric actuator
90-240 V AC 50-60 Hz

R	DN	*PN	E	H	L	Z	H ₁	H ₂	g	EPDM Code	FKM Code
2"1/2	65	6	157	211	30.2	150.6	82	187	3750	VXEFVEM212E	VXEFVEM212F
3"	80	6	174	248	33.3	181.4	93	202	6232	VXEFVEM300E	VXEFVEM300F
4"	100	6	212	283	39.3	204.4	93	202	8614	VXEFVEM400E	VXEFVEM400F

* PN10 upon request

DIMENSIONS

VXE/CE DN 65÷100 PVC-U

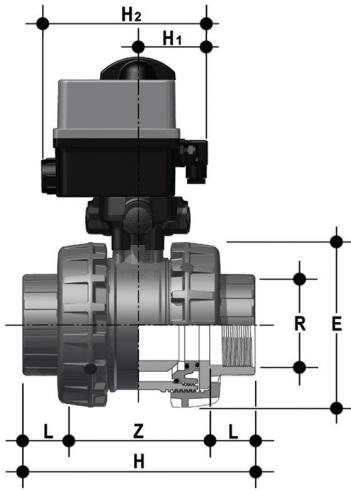

VXEFV/CE 24 V AC/DC

2 way Easyfit valve with female ends, gas cylinder thread with electric actuator 24 V AC/DC

R	DN	*PN	E	H	L	Z	H ₁	H ₂	g	EPDM Code	FKM Code
2"1/2	65	6	157	211	30.2	150.6	82	187	3750	VXEFVEL212E	VXEFVEL212F
3"	80	6	174	248	33.3	181.4	93	202	6232	VXEFVEL300E	VXEFVEL300F
4"	100	6	212	283	39.3	204.4	93	202	8614	VXEFVEL400E	VXEFVEL400F

* PN10 upon request

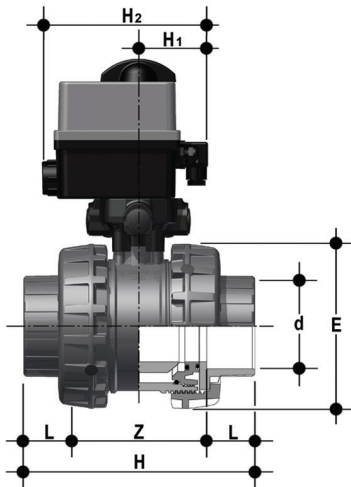

VXEJV/CE 90-240 V AC

2 way Easyfit valve with female ends for solvent welding, JIS series with multi-volt electric actuator 90-240 V AC 50-60 Hz

d	DN	*PN	E	H	L	Z	H ₁	H ₂	g	EPDM Code	FKM Code
2"1/2	65	6	157	243	61	121	82	187	3750	VXEJVEM212E	VXEJVEM212F
3"	80	6	174	272	64.5	143	93	202	6232	VXEJVEM300E	VXEJVEM300F
4"	100	6	212	332	84	164	93	202	8614	VXEJVEM400E	VXEJVEM400F

* PN10 upon request

DIMENSIONS

VXE/CE DN 65÷100 PVC-U

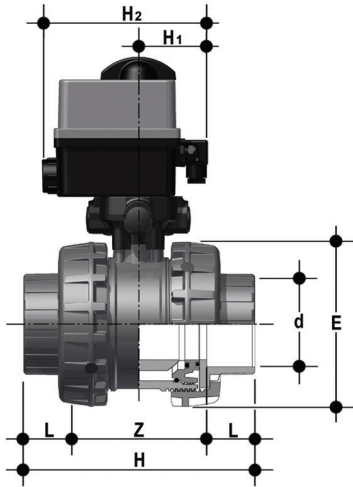

VXEJV/CE 24 V AC/DC

2 way Easyfit valve with female ends for solvent welding, JIS series with electric actuator 24V AC/DC

d	DN	*PN	E	H	L	Z	H ₁	H ₂	g	EPDM Code	FKM Code
2"1/2	65	6	157	243	61	121	82	187	3750	VXEJVVEL212E	VXEJVVEL212F
3"	80	6	174	272	64.5	143	93	202	6232	VXEJVVEL300E	VXEJVVEL300F
4"	100	6	212	332	84	164	93	202	8614	VXEJVVEL400E	VXEJVVEL400F

* PN10 upon request

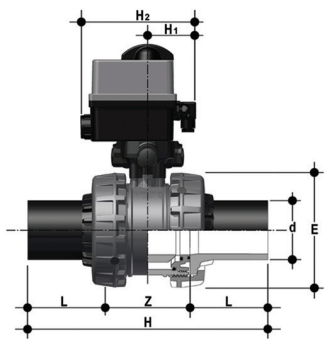

VXEBEV/CE 90-240 V AC

2-way Easyfit valve with PE100 SDR 11 male ends for butt welding or electrofusion welding (CVDE) with multi-volt electric actuator 90-240 V AC 50-60 Hz

d	DN	*PN	E	H	L	Z	H ₁	H ₂	g	EPDM Code	FKM Code
75	65	6	157	331	71	189	82	187	3286	VXEBEVEM075E	VXEBEVEM075F
90	80	6	174	367	88	191	93	202	5859	VXEBEVEM090E	VXEBEVEM090F
110	100	6	212	407	92	223	93	202	8273	VXEBEVEM110E	VXEBEVEM110F

* PN10 upon request

DIMENSIONS

VXE/CE DN 65÷100 PVC-U

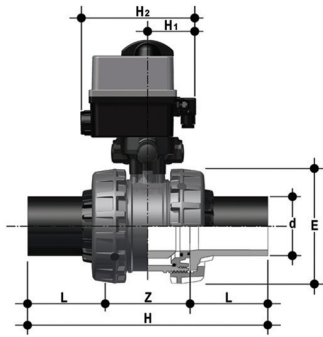

VXEBEV/CE 24 V AC/DC

2-way Easyfit valve with PE100 SDR 11 male ends for butt welding or electrofusion welding (CVDE) with electric actuator 24V AC/DC

d	DN	*PN	E	H	L	Z	H ₁	H ₂	g	EPDM Code	FKM Code
75	65	6	157	331	71	189	82	187	3286	VXEBEVEL075E	VXEBEVEL075F
90	80	6	174	367	88	191	93	202	5859	VXEBEVEL090E	VXEBEVEL090F
110	100	6	212	407	92	223	93	202	8273	VXEBEVEL110E	VXEBEVEL110F

* PN10 upon request

DIMENSIONS

VXE/CE DN 65÷100 PVC-C

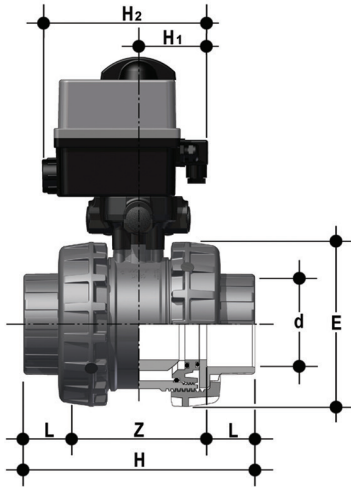

VXEIC/CE 90-240 V AC

2 way Easyfit valve with female ends for solvent welding, metric series with multi-volt electric actuator 90-240 V AC 50-60 Hz

d	DN	*PN	E	H	L	Z	H ₁	H ₂	g	EPDM Code	FKM Code
75	65	6	157	211	44	123	82	187	3998	VXEICEM075E	VXEICEM075F
90	80	6	174	248	51	146	93	202	6541	VXEICEM090E	VXEICEM090F
110	100	6	212	283	61	161	93	202	9137	VXEICEM110E	VXEICEM110F

* PN10 upon request

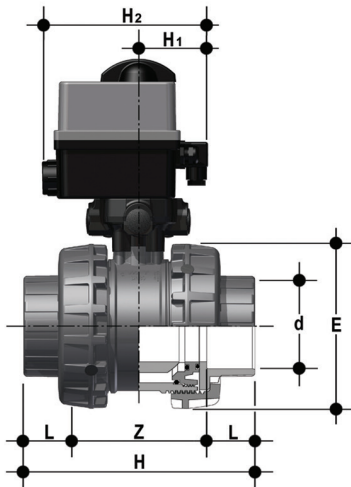

VXEIC/CE 24 V AC/DC

2 way Easyfit valve with female ends for solvent welding, metric series with electric actuator 24 V AC/DC

d	DN	*PN	E	H	L	Z	H ₁	H ₂	g	EPDM Code	FKM Code
75	65	6	157	211	44	123	82	187	3998	VXEICEL075E	VXEICEL075F
90	80	6	174	248	51	146	93	202	6541	VXEICEL090E	VXEICEL090F
110	100	6	212	283	61	161	93	202	9137	VXEICEL110E	VXEICEL110F

* PN10 upon request

DIMENSIONS

VXE/CE DN 65÷100 PVC-C

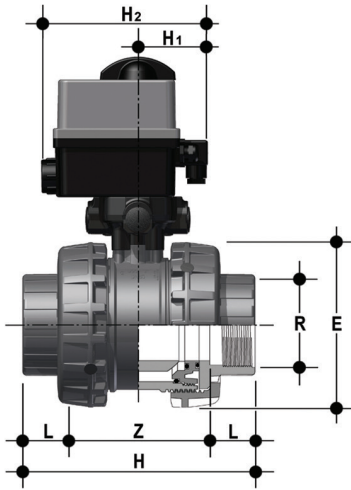

VXEFC/CE 90-240 V AC

2 way Easyfit valve with female ends, gas cylinder thread with multi-volt electric actuator
90-240 V AC 50-60 Hz

R	DN	*PN	E	H	L	Z	H ₁	H ₂	g	EPDM Code	FKM Code
2"1/2	65	6	157	211	30.2	150.6	82	187	3998	VXEFCCEM212E	VXEFCCEM212F
3"	80	6	174	248	33.3	181.4	93	202	6541	VXEFCCEM300E	VXEFCCEM300F
4"	100	6	212	283	39.3	204.4	93	202	9137	VXEFCCEM400E	VXEFCCEM400F

* PN10 upon request

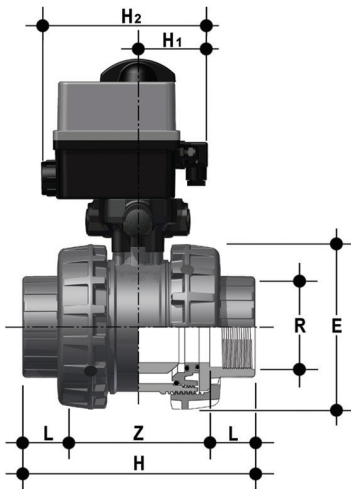

VXEFC/CE 24 V AC/DC

2 way Easyfit valve with female ends, gas cylinder thread with electric actuator 24 V AC/DC

R	DN	*PN	E	H	L	Z	H ₁	H ₂	g	EPDM Code	FKM Code
2"1/2	65	6	157	211	30.2	150.6	82	187	3998	VXEFCCEL212E	VXEFCCEL212F
3"	80	6	174	248	33.3	181.4	93	202	6541	VXEFCCEL300E	VXEFCCEL300F
4"	100	6	212	283	39.3	204.4	93	202	9137	VXEFCCEL400E	VXEFCCEL400F

* PN10 upon request

DIMENSIONS

VXE/CP DN 65÷100 PVC-U

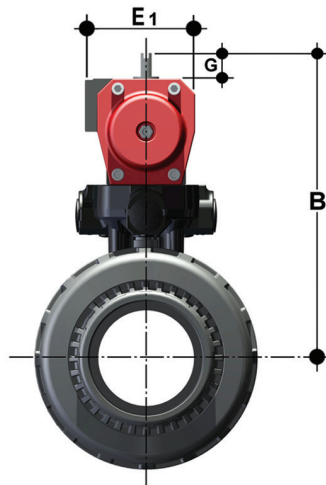

Dimensions common to all versions

DN	B	G	E ₁
65	232	20	86
80	239	20	86
100	276	30	94

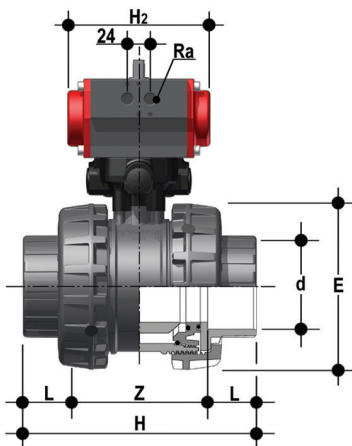

VXEIV/CP DA

2 way Easyfit valve with female ends for solvent welding, metric series with pneumatic actuator, Double-Acting function

d	DN	*PN	E	H	L	Z	H ₂	R _a	g	EPDM Code	FKM Code
75	65	6	157	211	44	123	155.5	G1/4"	4450	VXEIVDA075E	VXEIVDA075F
90	80	6	174	248	51	146	155.5	G1/4"	5132	VXEIVDA090E	VXEIVDA090F
110	100	6	212	283	61	161	210	G1/4"	8114	VXEIVDA110E	VXEIVDA110F

* PN10 upon request

DIMENSIONS

VXE/CP DN 65÷100 PVC-U

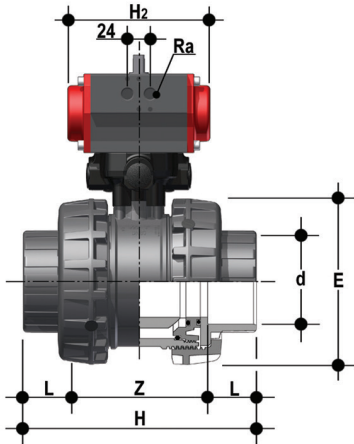

VXEIV/CP NC

2-way Easyfit valve with female ends for solvent welding, metric series with pneumatic actuator, Normally Closed function

d	DN	*PN	E	H	L	Z	H ₂	R _a	g	EPDM Code	FKM Code
75	65	6	157	211	44	123	210	G1/4"	5950	VXEIVNC075E	VXEIVNC075F
90	80	6	174	248	51	146	210	G1/4"	6632	VXEIVNC090E	VXEIVNC090F
110	100	6	212	283	61	161	210	G1/4"	9114	VXEIVNC110E	VXEIVNC110F

* PN10 upon request

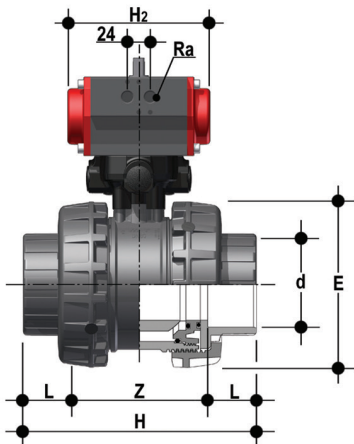

VXEIV/CP NO

2 way Easyfit valve with female ends for solvent welding, metric series with pneumatic actuator, Normally Open function

d	DN	*PN	E	H	L	Z	H ₂	R _a	g	EPDM Code	FKM Code
75	65	6	157	211	44	123	210	G1/4"	5950	VXEIVNO075E	VXEIVNO075F
90	80	6	174	248	51	146	210	G1/4"	6632	VXEIVNO090E	VXEIVNO090F
110	100	6	212	283	61	161	210	G1/4"	9114	VXEIVNO110E	VXEIVNO110F

* PN10 upon request

DIMENSIONS

VXE/CP DN 65÷100 PVC-U

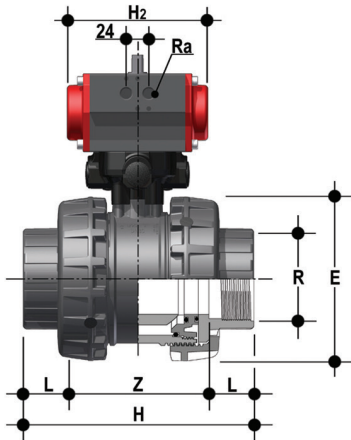

VXEFV/CP DA

2 way Easyfit valve with gas cylinder thread female ends with pneumatic actuator, Double-Acting function

R	DN	*PN	E	H	L	Z	H ₂	R ₀	g	EPDM Code	FKM Code
2"1/2	65	6	157	211	30.2	150.6	155.5	G1/4"	4450	VXEFVDA212E	VXEFVDA212F
3"	80	6	174	248	33.3	181.4	155.5	G1/4"	5132	VXEFVDA300E	VXEFVDA300F
4"	100	6	212	283	39.3	204.4	210	G1/4"	8114	VXEFVDA400E	VXEFVDA400F

* PN10 upon request

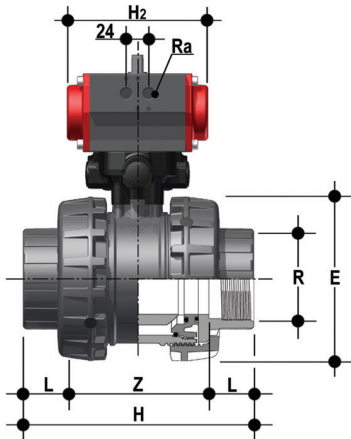

VXEFV/CP NC

2 way Easyfit valve with gas cylinder thread female ends with pneumatic actuator, Normally Closed function

R	DN	*PN	E	H	L	Z	H ₂	R ₀	g	EPDM Code	FKM Code
2"1/2	65	6	157	211	30.2	150.6	210	G1/4"	5950	VXEFVNC212E	VXEFVNC212F
3"	80	6	174	248	33.3	181.4	210	G1/4"	6632	VXEFVNC300E	VXEFVNC300F
4"	100	6	212	283	39.3	204.4	210	G1/4"	9114	VXEFVNC400E	VXEFVNC400F

* PN10 upon request

DIMENSIONS

VXE/CP DN 65÷100 PVC-U

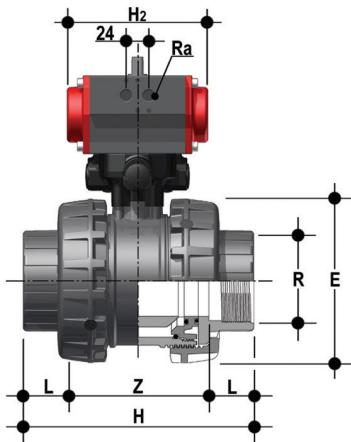

VXEFV/CP NO

2 way Easyfit valve with gas cylinder thread female ends with pneumatic actuator, Normally Open function

R	DN	*PN	E	H	L	Z	H ₂	R _o	g	EPDM Code	FKM Code
2"1/2	65	6	157	211	30.2	150.6	210	G1/4"	5950	VXEFVNO212E	VXEFVNO212F
3"	80	6	174	248	33.3	181.4	210	G1/4"	6632	VXEFVNO300E	VXEFVNO300F
4"	100	6	212	283	39.3	204.4	210	G1/4"	9114	VXEFVNO400E	VXEFVNO400F

* PN10 upon request

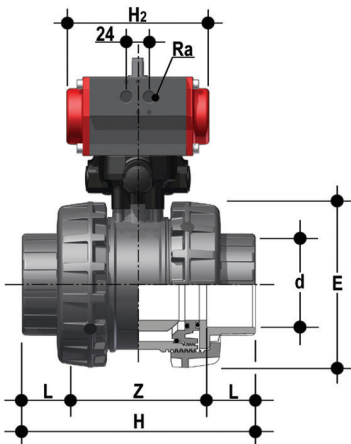

VXEJV/CP DA

2 way Easyfit valve with female ends for solvent welding, JIS series with pneumatic actuator, Double-Acting function

d	DN	*PN	E	H	L	Z	H ₂	R _o	g	EPDM Code	FKM Code
2"1/2	65	6	157	243	61	121	155.5	G1/4"	4450	VXEJVDA212E	VXEJVDA212F
3"	80	6	174	272	64.5	143	155.5	G1/4"	5132	VXEJVDA300E	VXEJVDA300F
4"	100	6	212	332	84	164	210	G1/4"	8114	VXEJVDA400E	VXEJVDA400F

* PN10 upon request

DIMENSIONS

VXE/CP DN 65÷100 PVC-U

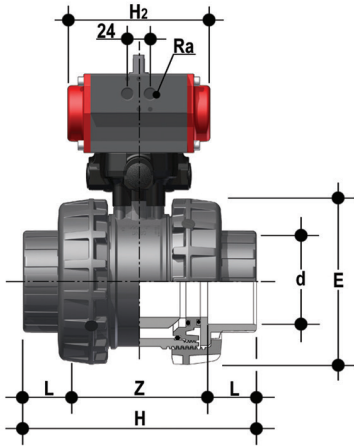

VXEJV/CP NC

2 way Easyfit valve with female ends for solvent welding, JIS series with pneumatic actuator, Normally Closed function

d	DN	*PN	E	H	L	Z	H ₂	R _a	g	EPDM Code	FKM Code
2"1/2	65	6	157	243	61	121	210	G1/4"	5950	VXEJVNC212E	VXEJVNC212F
3"	80	6	174	272	64.5	143	210	G1/4"	6632	VXEJVNC300E	VXEJVNC300F
4"	100	6	212	332	84	164	210	G1/4"	9114	VXEJVNC400E	VXEJVNC400F

* PN10 upon request

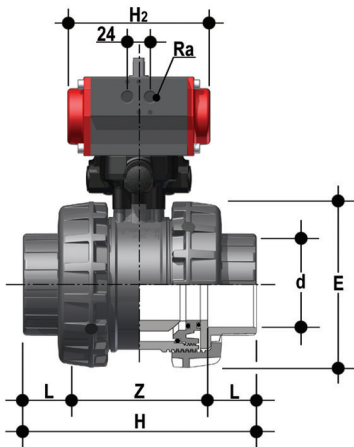

VXEJV/CP NO

2 way Easyfit valve with female ends for solvent welding, JIS series with pneumatic actuator, Normally Open function

d	DN	*PN	E	H	L	Z	H ₂	R _a	g	EPDM Code	FKM Code
2"1/2	65	6	157	243	61	121	210	G1/4"	5950	VXEJVNO212E	VXEJVNO212F
3"	80	6	174	272	64.5	143	210	G1/4"	6632	VXEJVNO300E	VXEJVNO300F
4"	100	6	212	332	84	164	210	G1/4"	9114	VXEJVNO400E	VXEJVNO400F

* PN10 upon request

DIMENSIONS

VXE/CP DN 65÷100 PVC-U

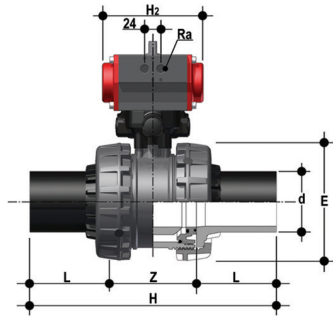

VXEBEV/CP DA

2-way Easyfit valve with PE100 SDR 11 male ends for butt welding or electrofusion welding (CVDE) with pneumatic actuator, Double-Acting function.

d	DN	*PN	E	H	L	Z	H ₂	R _a	g	EPDM Code	FKM Code
75	65	6	157	331	71	189	155.5	G1/4"	3986	VXEBEVDA075E	VXEBEVDA075F
90	80	6	174	367	88	191	155.5	G1/4"	4759	VXEBEVDA090E	VXEBEVDA090F
110	100	6	212	407	92	223	210	G1/4"	7773	VXEBEVDA110E	VXEBEVDA110F

* PN10 upon request

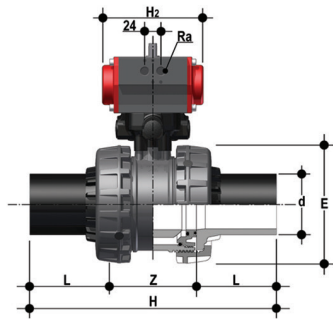

VXEBEV/CP NC

2-way Easyfit valve with PE100 SDR 11 male ends for butt welding or electrofusion welding (CVDE) with pneumatic actuator, Normally Closed function.

d	DN	*PN	E	H	L	Z	H ₂	R _a	g	EPDM Code	FKM Code
75	65	6	157	331	71	189	155.5	G1/4"	5486	VXEBEVNC075E	VXEBEVNC075F
90	80	6	174	367	88	191	155.5	G1/4"	6259	VXEBEVNC090E	VXEBEVNC090F
110	100	6	212	407	92	223	210	G1/4"	8773	VXEBEVNC110E	VXEBEVNC110F

* PN10 upon request

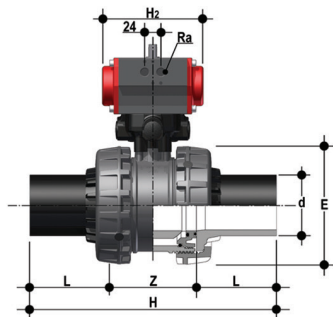

VXEBEV/CP NO

2-way Easyfit valve with PE100 SDR 11 male ends for butt welding or electrofusion welding (CVDE) with pneumatic actuator, Normally Open function.

d	DN	*PN	E	H	L	Z	H ₂	R _a	g	EPDM Code	FKM Code
75	65	6	157	331	71	189	155.5	G1/4"	5486	VXEBEVNO075E	VXEBEVNO075F
90	80	6	174	367	88	191	155.5	G1/4"	6259	VXEBEVNO090E	VXEBEVNO090F
110	100	6	212	407	92	223	210	G1/4"	8773	VXEBEVNO110E	VXEBEVNO110F

* PN10 upon request

DIMENSIONS

VXE/CP DN 65÷100 PVC-C

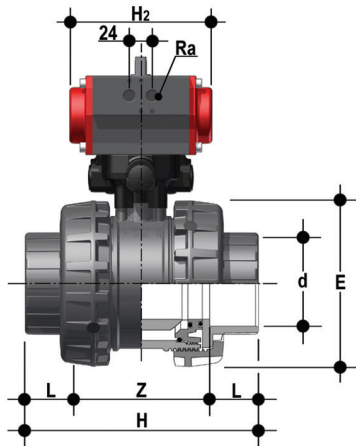

VXEIC/CP DA

2 way Easyfit valve with female ends for solvent welding, metric series with pneumatic actuator, Double-Acting function

d	DN	*PN	E	H	L	Z	H ₂	R _a	g	EPDM Code	FKM Code
75	65	6	157	211	44	123	155.5	G1/4"	4698	VXEICDA075E	VXEICDA075F
90	80	6	174	248	51	146	155.5	G1/4"	5441	VXEICDA090E	VXEICDA090F
110	100	6	212	283	61	161	210	G1/4"	8637	VXEICDA110E	VXEICDA110F

* PN10 upon request

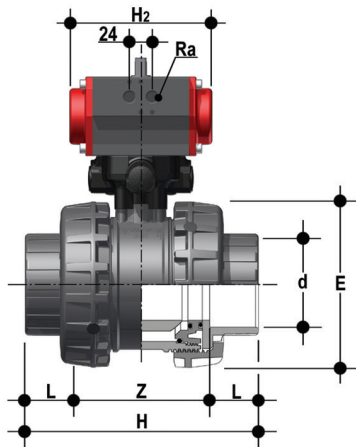

VXEIC/CP NC

2 way Easyfit valve with female ends for solvent welding, metric series with pneumatic actuator, Normally Closed function

d	DN	*PN	E	H	L	Z	H ₂	R _a	g	EPDM Code	FKM Code
75	65	6	157	211	44	123	210	G1/4"	6198	VXEICNC075E	VXEICNC075F
90	80	6	174	248	51	146	210	G1/4"	6941	VXEICNC090E	VXEICNC090F
110	100	6	212	283	61	161	210	G1/4"	9637	VXEICNC110E	VXEICNC110F

* PN10 upon request

DIMENSIONS

VXE/CP DN 65÷100 PVC-C

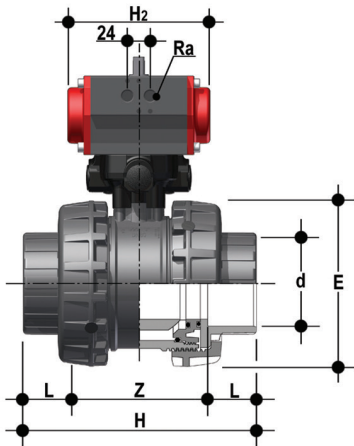

VXEIC/CP NO

2 way Easyfit valve with female ends for solvent welding, metric series with pneumatic actuator, Normally Open function

d	DN	*PN	E	H	L	Z	H ₂	R _o	g	EPDM Code	FKM Code
75	65	6	157	211	44	123	210	G1/4"	6198	VXEICNO075E	VXEICNO075F
90	80	6	174	248	51	146	210	G1/4"	6941	VXEICNO090E	VXEICNO090F
110	100	6	212	283	61	161	210	G1/4"	9637	VXEICNO110E	VXEICNO110F

* PN10 upon request

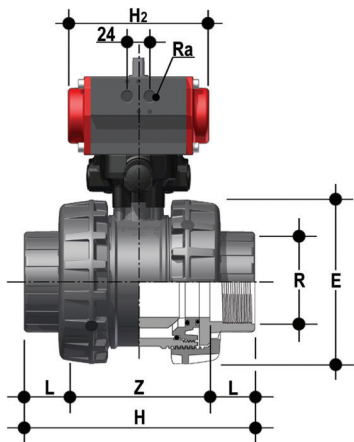

VXEFC/CP DA

2 way Easyfit valve with gas cylinder thread female ends with pneumatic actuator, Double-Acting function

R	DN	*PN	E	H	L	Z	H ₂	R _o	g	EPDM Code	FKM Code
2"1/2	65	6	157	211	30.2	150.6	155.5	G1/4"	4698	VXEFCDA212E	VXEFCDA212F
3"	80	6	174	248	33.3	181.4	155.5	G1/4"	5441	VXEFCDA300E	VXEFCDA300F
4"	100	6	212	283	39.3	204.4	210	G1/4"	8637	VXEFCDA400E	VXEFCDA400F

* PN10 upon request

DIMENSIONS

VXE/CP DN 65÷100 PVC-C

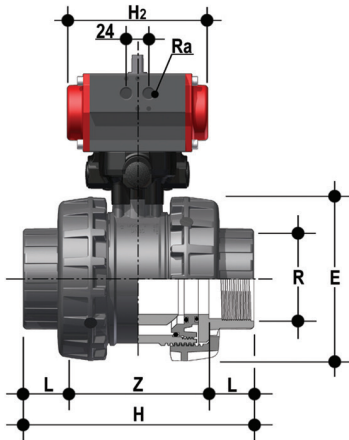

VXEFC/CP NC

2 way Easyfit valve with gas cylinder thread female ends with pneumatic actuator, Normally Closed function

R	DN	*PN	E	H	L	Z	H ₂	R _a	g	EPDM Code	FKM Code
2"1/2	65	6	157	211	30.2	150.6	210	G1/4"	6198	VXEFCNC212E	VXEFCNC212F
3"	80	6	174	248	33.3	181.4	210	G1/4"	6941	VXEFCNC300E	VXEFCNC300F
4"	100	6	212	283	39.3	204.4	210	G1/4"	9637	VXEFCNC400E	VXEFCNC400F

* PN10 upon request

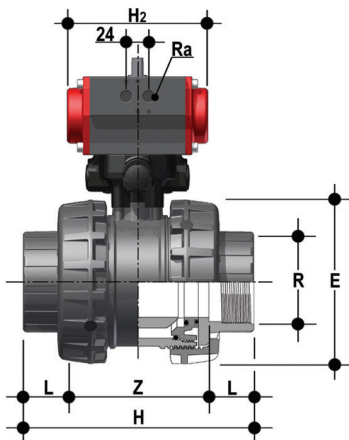

VXEFC/CP NO

2 way Easyfit valve with gas cylinder thread female ends with pneumatic actuator, Normally Open function

R	DN	*PN	E	H	L	Z	H ₂	R _a	g	EPDM Code	FKM Code
2"1/2	65	6	157	211	30.2	150.6	210	G1/4"	6198	VXEFCNO212E	VXEFCNO212F
3"	80	6	174	248	33.3	181.4	210	G1/4"	6941	VXEFCNO300E	VXEFCNO300F
4"	100	6	212	283	39.3	204.4	210	G1/4"	9637	VXEFCNO400E	VXEFCNO400F

* PN10 upon request

COMPONENTS

EXPLODED VIEW

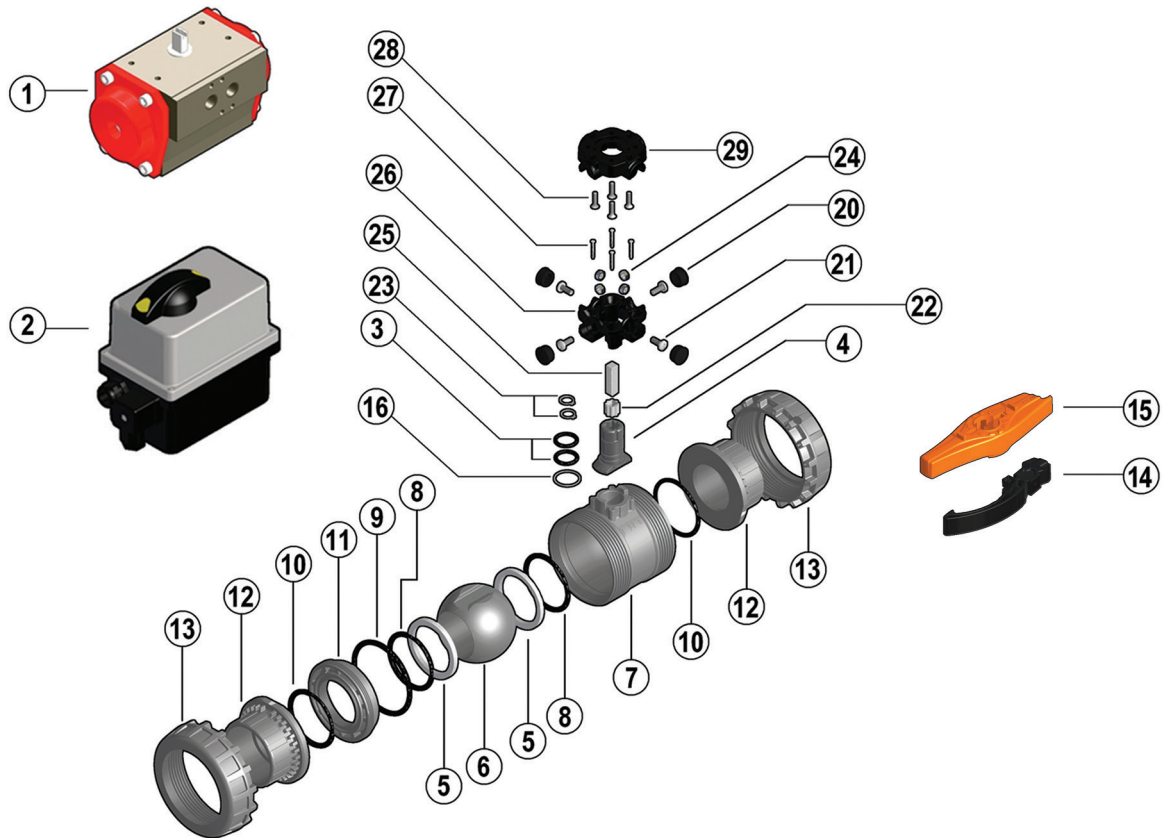

- | | | |
|--|--|--|
| 1 Pneumatic actuator (Finished aluminium - 1) | 9 Radial seal O-Ring (FKM, EPDM - 1)* | 20 Protection plug (PP - 4) |
| 2 Electric actuator (PA6-Nylon - 1) | 10 Socket seal O-Ring (EPDM-FKM - 2)* | 21 Screw (STAINLESS steel - 4) |
| 3 Stem O-Ring (FKM, EPDM - 2)* | 11 Ball seat carrier (PVC-U / PVC-C - 1)* | 22 Reduction (STAINLESS steel - 1) |
| 4 Stem (PVC-U / PVC-C - 1)* | 12 End connector (PVC-U / PVC-C - 2) | 23 Seeger ring (STAINLESS steel - 2) |
| 5 Ball seal (PTFE - 2)* | 13 Union nut (PVC-U / PVC-C - 2)* | 24 Nut (stainless steel - 4) |
| 6 Ball (PVC-U / PVC-C - 1)* | 14 Hooked Easyfit multifunctional handle insert (PP-GR - 1) | 25 Connection rod (/stainless steel -1) |
| 7 Body (PVC-U / PVC-C - 1) | 15 Easyfit multifunctional handle (HIPVC - 1) | 26 Lower plate (PP-GR - 1) |
| 8 Ball seat O-Ring (FKM, EPDM - 2)* | 16 Anti-friction disk (PTFE - 1)* | 27 Screw (STAINLESS steel - 4) |
| | | 28 Screw (STAINLESS steel - 4) |
| | | 29 Upper plate (PP-GR - 1) |

* Spare parts

The material the component is made of and the quantity supplied are shown in brackets

DISASSEMBLY

- 1) Isolate the valve from the line (release the pressure and empty the pipeline).
- 2) Disconnect the actuator from the compressed air supply and/or power mains.
- 3) Remove the screws (21) and lift the actuator (1/2) with the plate (29).
- 4) Use the Easyfit multifunctional handle (14/15) (fig. 3/4) as a wrench to fully unscrew the union nuts (13) (fig.5) from the valve body and laterally remove the body (7) (fig. 1).
- 5) Before dismantling, hold the valve in a vertical position and open it 45° to drain any liquid that might remain.
- 6) Open the valve.
- 7) Remove the ball seat carrier (11) using the Easyfit quick release handle. Insert the two protrusions at the top of the handle (15) in the seat carriers (11) and unscrew, extracting it by turning counter-clockwise (fig. 2).
- 8) Press on the ball from the side opposite the "REGULAR" label, being sure not to scratch it, until the ball seat exits (5), then extract the ball (6).
- 9) Press the stem inwards and extract it from the body and remove the anti-friction disk (16).
- 10) Remove the O-Ring (3, 8, 9, 10) and ball seats (5) extracting them from their seats, as illustrated in the exploded view.

ASSEMBLY

- 1) All the O-rings (3, 8, 9, 10) must be inserted in their grooves as shown in the exploded view.
- 2) Place the anti-friction disk (16) on the stem (4) and insert it in the body (7).
- 3) Place the PTFE ball seats (5) in the housings in the body (7) and in the ball seat carrier (11).
- 4) Insert the ball (6) rotating it to the closed position.
- 5) Screw the carrier (11) into the body and tighten up in the clockwise direction using the handle (15) to limit stop.
- 6) Position the valve between the end connectors (12) and tighten the union nuts clockwise (13) using the Easyfit multifunctional handle (14/15) (fig. 5) and being sure the socket seal O-rings (10) do not exit the seats.
- 7) Reassemble the actuator (1/2) with plate (29) on the valve making sure the ball position (6) and actuator stem are aligned.
- 8) Tighten the screws (21) and reconnect the actuator to the pneumatic and/or power supplies.



All operations on equipment under pressure or containing compressed springs must be carried out under safe conditions for the operator.

Note: during mounting operations, it is advisable to lubricate the rubber seals. Mineral oils are not recommended for this task as they react aggressively with EPDM rubber.

The photos refer to the manual version and are purely exemplary.

Fig. 1



Fig. 2



Fig. 3



Fig. 4



INSTALLATION

Before proceeding with installation, please follow these instructions carefully:

- 1) Check that the pipes to be connected to the valve are aligned in order to avoid mechanical stress on the threaded joints.
- 2) Unscrew the union nuts (13) from the body (7) and insert them in the pipe segments.
- 3) Solvent weld or screw the end connectors (12) onto the pipe segments.
- 4) Position the valve body between the end connectors.
Warning: if a high pressure test is required, always position the body with the "REGULAR" label upstream from the fluid direction.
- 5) Place the union nuts on the valve body and start tightening manually clockwise until they are hard to turn. To complete tightening, use the Easyfit multifunctional handle (14/15).
- 6) Extract the hooked insert (14) in the handle (fig. 3) overturn it and fit it in the seat on the lower part of the handle (fig. 4).
- 7) Fit the tool on the external union nut profile until firmly and safely secured that allows for adequate torque without damaging the union nut in any way (fig. 5).
- 8) Repeat point 7 for the other union nut.
- 9) If necessary, support pipes with FIP pipe clip model ZIKM and DSM spacers.

WARNINGS

- If volatile liquid such as Hydrogen Peroxide (H₂O₂) or Sodium Hypochlorite (NaClO) is used, for safety reasons we recommend you contact the service centre. These liquids, upon vaporising, could create hazardous over pressures in the area between the body and ball.
- Always avoid sudden closing manoeuvres that can generate water hammer. For this reason, we recommend you equip pneumatic actuators with air speed reducers.

Fig.5

